

Electronic Pedal LOGOS Series

Hall-Effect Electronic Pedal – LOGOS Series



DISTINCTIVE FEATURES

- Compact, ideal for confined spaces
- Versatile, configurable according to needs
- Reliable, the signal doesn't drift out of calibration
- Ergonomic, mounting under the board so that it does not clutter up space
- Protection degree: IP 67

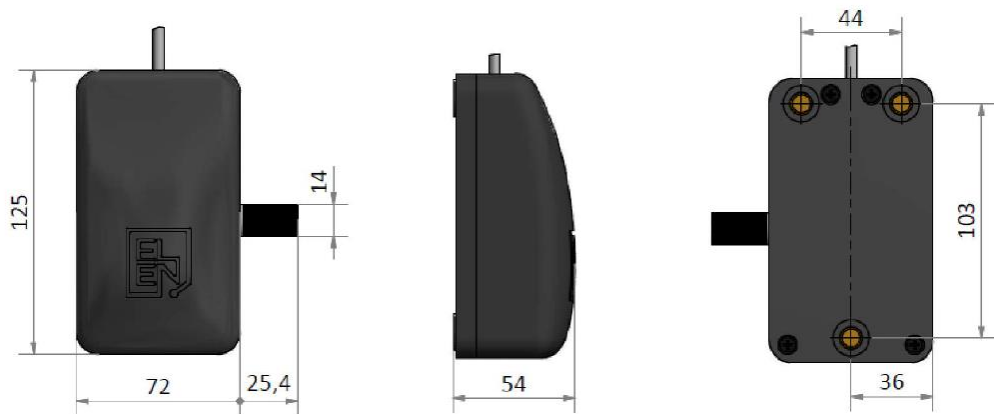
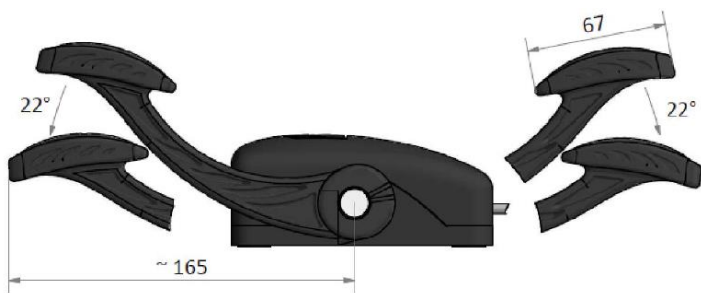

Product concept – LOGOS Series

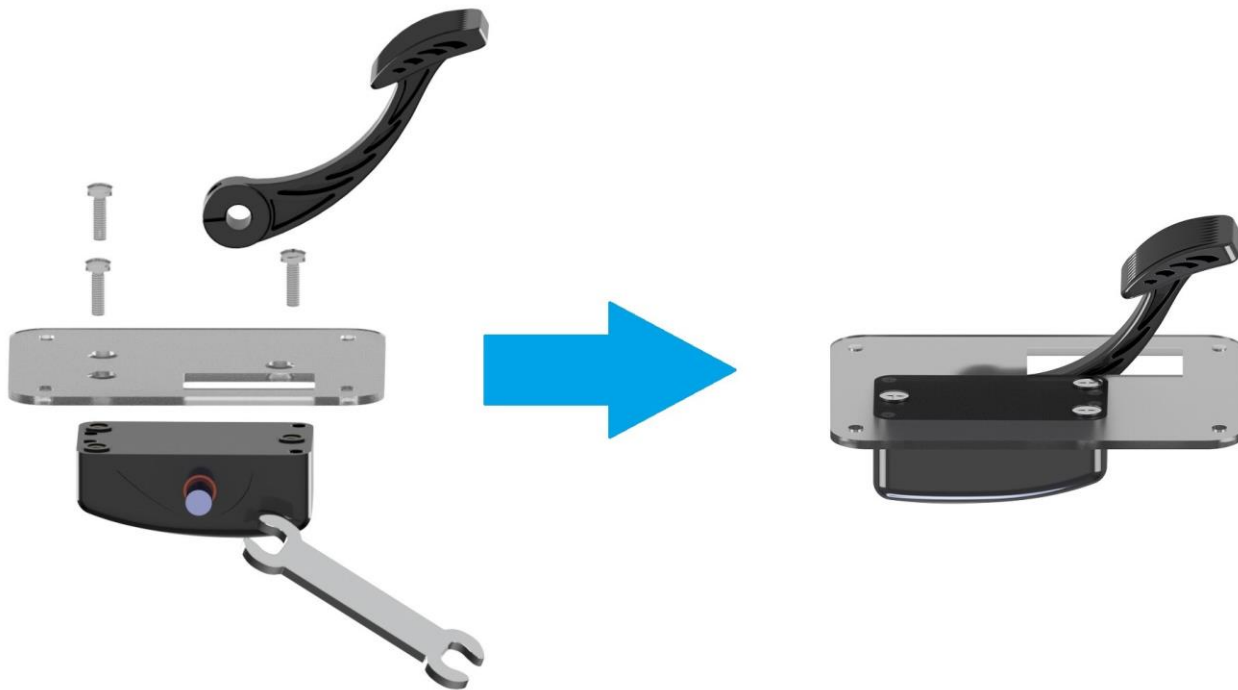

The Logos series electronic pedals are extremely versatile and suitable for both vertical mounting and under-the-platform mounting, with the lever in the right or left position, thanks to two simple measures: the rotation direction invertibility of the lever's pin and the mechanical modularity of the lever.

The lever can be designed and installed directly by customers, in accordance with their specific design and ergonomic requirements.

Hall-Effect Electronic Pedals – Overall features

GENERAL DESCRIPTION

Elen's electronic accelerator pedals combine design, precision and solidity. The position of the platform is detected by a contactless Hall effect sensor which is integrated in the structure, and provides a slope proportional signal.

Elen's electronic pedals combine mechanical robustness and measurement reliability.

BEST USES

- Accelerator pedal for electronically controlled diesel engines subjected to emission standards from Stage IIIB on.
- Accelerator pedal for electrically-driven vehicles
- Inching pedal for work vehicles with hydrostatic transmission
- Compliance of control devices with functional safety standards
- Implementation of electronic drive-by-wire devices
- Use of a reliable device in harsh environments
- Technological upgrade of control pedals
- Cost saving and space optimization for replacement of pedal solutions with separate sensor
- Plug and play solution with integrated electronics

Hall-Effect Electronic Pedals – Overall features

HALL EFFECT TECHNOLOGY

An hall-effect sensor, integrated in the housing of the pedal, detects the field strength of a magnet integral with the footboard. It guarantees a reliable signal and immune to premature failures due to mechanical wear.

INTEGRATED ARCHITECTURE

The magnet - integral with the footboard - and the electronic board - integral with the housing - are positioned in the optimal position to reduce overall dimensions and remove moving connecting parts as well as redundant mechanical components.

INDEPENDENT CIRCUITS

Double output versions are obtained by integrating on the same electronic support two sensors with completely independent and galvanically isolated circuits, in compliance with functional safety standards.

PROGRAMMABLE ELECTRONIC BOARD

The programmable electronic board allows to set up the output signal values and the trigger threshold for the switch signal without hardware interventions and manual calibrations. It guarantees the highest level of reliability, precision and versatility.

MULTIFUNCTION BOARD

The output signal and the running consent signal circuits are integrated on a single contactless electronic board without any need for elements subject to wear, like microswitches and other mechanical connections.

RESIN-COATED BOARD COMPARTMENT

It ensures absolute impermeability to water/dust/corrosive agents infiltrations and makes the electronic board compartment a completely sealed subassembly of the product structure.

RETURN TO STARTING POSITION

It is implemented to maintain the minimum overall dimensions and at the same time to guarantee the redundancy of the springs, a suitable operating load as well as a high life cycle.

Hall-Effect Electronic Pedals – CAN J1939 Output



CAN J1939

Output Signal

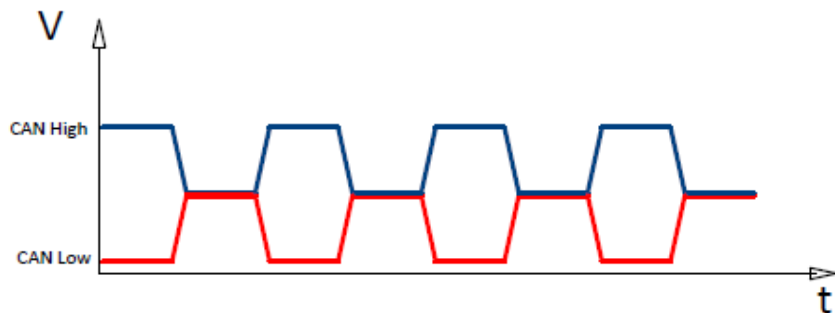

Functional Scheme

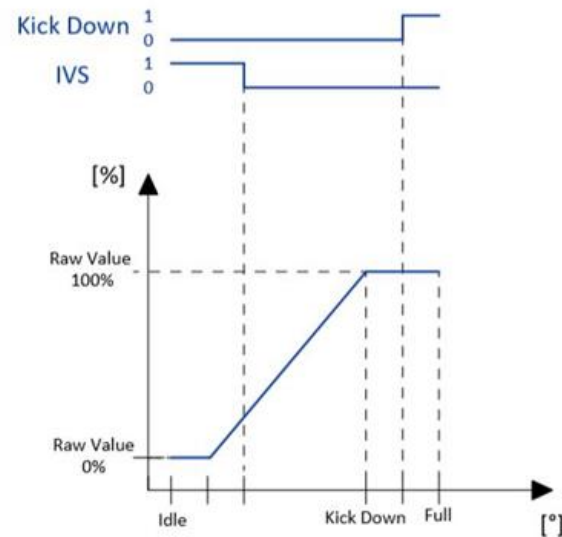
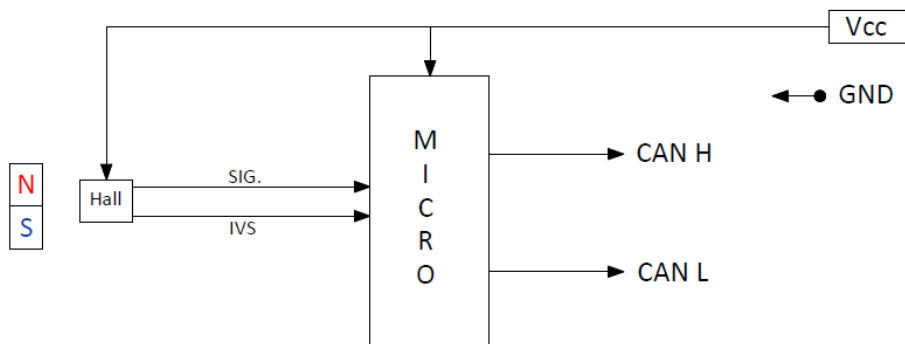

Hall-Effect Electronic Pedals – Other output configurations

SINGLE SIGNAL

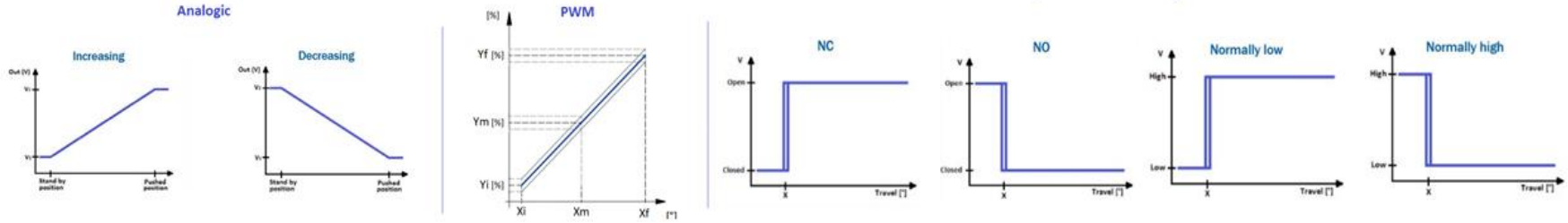

DOUBLE SIGNAL

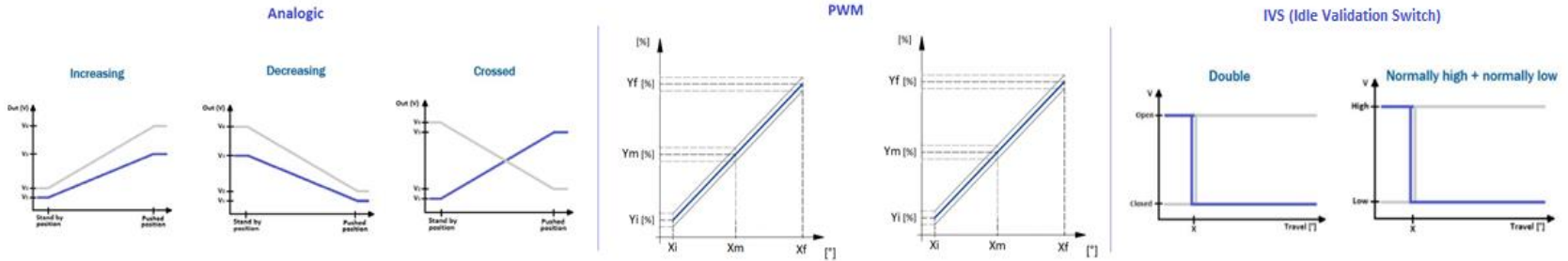

General features of ELEN products

1. ELEN S.r.l. designs and manufactures hall-effect electronic sensors and input devices **specifically intended for industrial vehicle sectors and agricultural machinery** .
2. Besides a standard products offer, it provides with the most specific and **innovative solutions** for any application, giving particular focus on the most recent R&D developments and promptly meeting the new market needs.
3. The company know-how, the market analysis, the **strong and direct customer relationship** allow to introduce cutting edge solutions in accordance with **sector's standards and regulations**, offering a products portfolio that distinguishes ELEN from its competitors.

